

December 11, 2007

Re: Electomechanical Drive Circuit

An electromechanical transducer is capable of creating a wide range of sounds from direct frequencies, sweeps, ticks, tonal music and sounds.

The driving of an EM transducer requires an input signal, zero to peak, square wave is best for higher SPL, sine wave works well for softer tones, applied to one terminal of the product, with the second terminal going either to ground or VCC, depending on the configuration. If the drive signal has sufficient current, then connecting that signal to the + terminal of the device will supply the desired output, but if sufficient current output is not available, as in deriving the drive signal from a processor, the use of a transistor drive circuit will be required.

The circuit diagram below shows the standard transistor drive circuit configuration when driven from a processor.

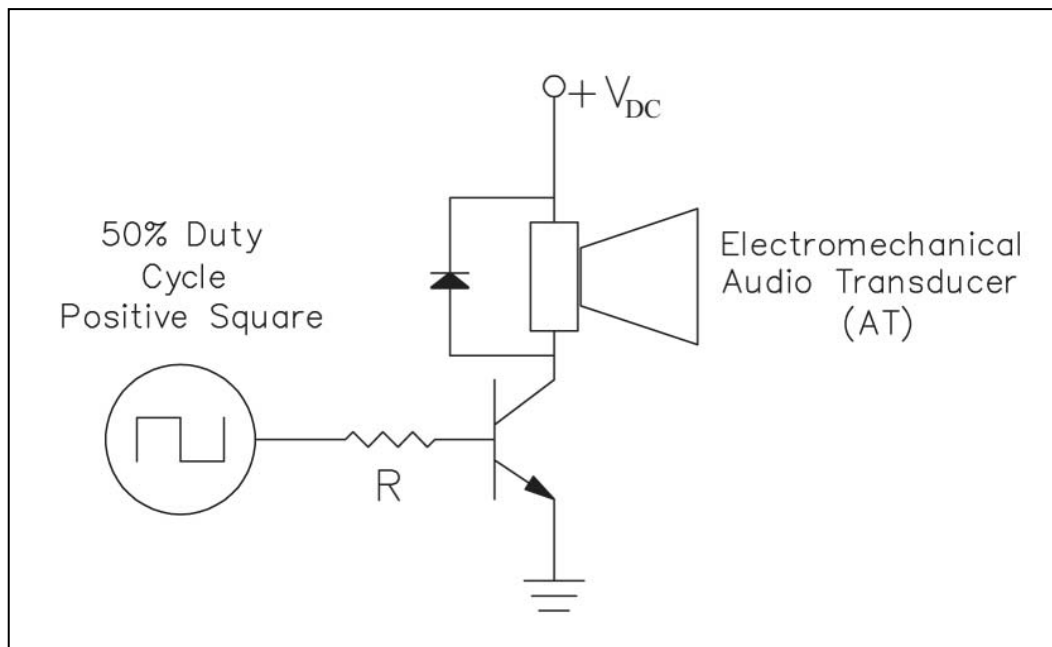

The positive terminal can be connected directly to the battery voltage as long as that voltage is within the operating voltage range. The input to the base of the transistor should be as high a voltage as can be provided from the processor, to ensure that the transistor is driven hard to ground to allow the transducer to oscillate at the input frequency.

The transducer should be a fast switching transducer with a high Hfe. The 2N2222A works well in this application.